



SRI MANAKULA VINAYAGAR
ENGINEERING COLLEGE
(An Autonomous Institution)

Puducherry

Regulations R-2023
for
M.Tech. Degree Programme
(With effect from academic year 2023-24)



Vision and Mission

Vision

To be globally recognized for excellence in quality education, innovation and research for the transformation of lives to serve the society.

Mission

M1: Quality Education :To provide comprehensive academic system that amalgamates the cutting edge technologies with best practices.

M2: Research and Innovation : To foster value-based research and innovation in collaboration with industries and institutions globally for creating intellectuals with new avenues.

M3: Employability and Entrepreneurship : To inculcate the employability and entrepreneurial skills through value and skill based training.

TABLE OF CONTENTS

| | | |
|-----|---|----|
| 1. | Introduction | 5 |
| 2. | Preliminary Definitions and Nomenclature..... | 6 |
| 3. | Branches of Study..... | 8 |
| 4. | Eligibility for Admission | 8 |
| 5. | Academic Structure..... | 8 |
| 6. | Curriculum Structure | 8 |
| 7. | Course Enrolment and Registration..... | 11 |
| 8. | Assessment Procedures for Awarding Marks | 12 |
| 9. | Eligibility for Appearing End Semester Examination..... | 17 |
| 10. | Requirements for Passing the Examination..... | 18 |
| 11. | Evaluation and Grievance Redressal Mechanism..... | 19 |
| 12. | Letter Grade and Grade Sheet..... | 19 |
| 13. | Eligibility for the Award of Degree | 20 |
| 14. | Temporary Break of Study from the Programme..... | 21 |
| 15. | Termination from the Programme..... | 21 |
| 16. | Discipline and Conduct..... | 21 |
| 17. | Academic Calendar..... | 23 |
| 18. | Various Committees and its Functions..... | 23 |
| 19. | Revision of Regulations and Curriculum..... | 29 |



SRI MANAKULA VINAYAGAR ENGINEERING COLLEGE

(An Autonomous Institution)

MASTER OF TECHNOLOGY PROGRAMMES
(Four Semesters)

REGULATIONS 2023 (R-2023)

CHOICE BASED CREDIT SYSTEMS (CBCS)

(Common to all M.Tech. Programmes)

1. INTRODUCTION

- 1.1 Sri Manakula Vinayagar Engineering College (SMVEC) envisions to foster knowledge, skills, attitude and values of the aspiring youth to enable them to become global citizens. To achieve this process, the institution has evolved a flexible integrated academic curriculum designed in accordance with the Outcome Based Education (OBE) which is acquired by the learners of a programme under 'Learner Centric' Model.
- 1.2 All the Post Graduate Engineering programme shall be governed by the rules and regulations provided in this version of Academic Regulations (R-2023). The curriculum of each programme provides broad based knowledge, quality course content, academic flexibility, and scope for multi-disciplinary learning activities and opportunities for industry oriented projects.
- 1.3 The provisions made in this document shall govern the policies, procedures, curriculum, conduct of the examinations and evaluation systems
- 1.4 The semester system shall be adopted for academic activities in the college. Normally, odd semester starts in second week of June and even semester starts in second week of December.
- 1.5 Stringent evaluation norms will be followed to maintain quality of engineering education. The examination system will be transparent and governed by the rules and regulations with time bounded activities.

Objectives of CBCS

- ❖ To shift focus from the teacher-centric to student-centric education.
- ❖ To allow students to choose inter-disciplinary, intra-disciplinary and skill oriented courses from the choices to provide more flexibility in learning system.
- ❖ To make education broad-based on par with global standards.
- ❖ To help students to earn credits by choosing unique combination of courses.
- ❖ To create an Worldwide exposure to students by providing International Certificate Courses.
- ❖ To provide necessary training to students for gaining vital life skills through skill development programmes.
- ❖ To keep abreast of industrial requirements and societal needs, students are equipped through internship and inculcate the skill of converting Project into

Product.

- 1.6 The rules and regulations shall be subjected to amendment made by the Academic Council (AC) from time to time.

2. PRELIMINARY DEFINITIONS AND NOMENCLATURE

| | | |
|---------------------------------------|---|--|
| College | : | Sri Manakula Vinayagar Engineering College |
| University | : | Pondicherry University |
| Programme | : | M.Tech. Degree |
| Specialization | : | Specialization of M.Tech Degree Programme like ECE, CSE, VLSI and Embedded Systems, Manufacturing, Artificial intelligence and Data Science, Computer Science Engineering(Big Data Analytics), etc., |
| Course | : | Theory / Practical subject that is normally studied in a semester. Eg: Advanced Mathematics for Electrical Engineers, Nano Electronics, etc., |
| Professional Core Course | : | Compulsory course in the curriculum |
| Professional Elective Course | : | A course that can be chosen from the listed courses by a student based on his/her interest which is not covered in professional core courses. |
| Head of the Institution | : | The Director cum Principal |
| Controller of Examinations (CoE) | : | The authority who is responsible for all Examination related activities of the institution |
| L – T – P – C | : | L - Lecture, T - Tutorial, P - Practical, and C - Credits respectively |
| Curriculum | : | The various components / courses studied in each programme that provides an appropriate outcome in the chosen branch of study. |
| Semester Grade Point Average (SGPA) | : | Weightage of average grade points of subjects in a semester. |
| Cumulative Grade Point Average (CGPA) | : | Weightage of average grade points of all subjects in all semesters completed by a student |
| Odd semester | : | The semester that is typically from June to November |
| Even semester | : | The semester that is typically from December to May |
| Period | : | 50 minutes duration of a theory / practical class |
| Day | : | 8 periods in a calendar day |
| Enrolment | : | Enlistment of a student on roll in an academic year |
| Arrear | : | A course in which a student has not fulfilled the examination passing criteria in the end semester examination. |
| CAT | : | Continuous Assessment Test |
| CAM | : | Continuous Assessment Marks |
| ESE | : | End Semester Examination |

| | | |
|---|---|---|
| ESM | : | End Semester Examination Marks |
| AEC | : | Ability Enhancement Course |
| Regular Examination | : | End semester examination conducted for the courses prescribed in the curriculum of that semester |
| Arrear Examination | : | End Semester examination conducted for the students who have not fulfilled the examination passing criteria in the previous attempt(s). |
| First Attempt | : | Appearing for the end semester examination of a course in a semester for which the students have registered. If a student failed to appear for the end semester examination after registration, it is also treated as first attempt |
| Academic Council (AC) | : | An Apex academic body having the power to scrutinize and approve the proposals with or without modification of the Board of Studies with regard to courses of study, academic regulations, curricula, syllabi and modifications thereof, instructional and evaluation arrangements, methods, procedures relevant thereto, etc. |
| Board of Studies (BoS) | : | An Apex academic body having the powers to approve the various courses, suggest teaching methodologies, coordinate research and other academic activities keeping in view the objectives of the college. |
| Academic Standing Committee (ASC) | : | ASC shall perform the functions under emergent situations which are subject to ratification by the Academic Council (AC). |
| Academic Appeal Board (AAB) | : | If a student finds some anomaly in the award of marks in Continuous Assessment Test /End Semester examination, he/she can make an appeal to the <i>Academic Appeal Board</i> for review of marks awarded. |
| Department Advisory Committee (DAC) | : | The Committee that formulates a process to review the post implementation effects of curriculum and suggest various measures to ensure academic standard and its excellency of the course offered by the department. |
| Department Consultative Committee (DCC) | : | Reviews, revises and prepares curriculum structure based on the institutional policy and suggests improvements in syllabus of a course(s) prepared by course teacher(s) and forwards the curriculum to BoS for further recommendations. It monitors the academic progress and conduct of classes throughout the semester and takes appropriate corrective measures to improve the quality of curriculum delivery. |
| Programme Academic Coordinator (PAC) | : | Coordinates all the academic activities of the department viz. Curriculum revision, framing of syllabus, time table, re-registration of course(s), display and submission of attendance status and BoS meeting as a member secretary. |
| PG Coordinator | : | Encourage students and keep a careful eye on their progress. Work closely with the student on matters pertaining to the student, and periodically update the information in the student's profile for future use. |

| | | |
|-------|---|---|
| AICTE | : | All India Council for Technical Education |
| UGC | : | University Grants Commission |
| NBA | : | National Board of Accreditation |
| NAAC | : | National Assessment and Accreditation Council |
| CRC | : | Complaint Redressal Committee |

3. BRANCHES OF STUDY

Sri Manakula Vinayagar Engineering College offers the following M.Tech. Degree Programmes:

1. M.Tech - Electronics and Communication Engineering
2. M.Tech - Computer Science and Engineering
3. M.Tech - VLSI and Embedded Systems
4. M.Tech - Manufacturing Engineering
5. M.Tech – Artificial Intelligence and Data Science
6. M.Tech – Computer Science Engineering (Big Data Analytics)

4. ELIGIBILITY FOR ADMISSION

The norms for admission, eligibility criteria such as marks, age limit and mode of admission will be as prescribed by the Pondicherry University from time to time.

4.1 Educational Eligibility

Candidates for admission to the first semester of M.Tech. Degree programme shall be required to satisfy the eligibility rules prescribed by All India Council for Technical Education (AICTE) and Pondicherry University, and Government of Puducherry as notified from time to time with at least 50% marks in the degree examination or equivalent CGPA (45% marks in case of candidates belonging to reserved category).

4.2 Age Limit

There is no age limit for the M.Tech programmes.

5 ACADEMIC STRUCTURE

5.1 Duration of the Programme

A student after securing admission shall pursue M.Tech programme for a minimum period of 2 academic years (4 semesters), if not he / she has to complete the degree within the maximum period of 4 years (8 semesters) starting from the commencement of the first semester.

5.2 Medium of Instruction

The medium of instruction for the entire M.Tech. Degree programme shall be only in **ENGLISH**.

6 CURRICULUM STRUCTURE

According to the National Board of Accreditation (NBA), the curriculum has to be evolved after finalizing the Programme Educational Objectives (PEOs) and the corresponding Programme Outcomes (POs). The Programme Specific Outcomes (PSOs) are to be evolved based on the knowledge and skills developed over the duration of programme. The curriculum that evolves should broadly ensure the achievement of the POs and PSOs, and thus the PEOs of the programme.

6.1 Category of Courses and its Credit Distribution

Course work is measured in units called credit hours or simply credits. One credit per lecture hour per week is assigned for each theory course. Laboratory courses are

assigned for an hour with 0.5 credits per week. The credits details of courses are shown in Table 1.

Table 1 Credits details of courses

| Nature of Course | Number of hours | | | Credits |
|--------------------------------|-----------------|------------------|----|---------|
| | L | T | P | |
| Theory | 3 | 0 | 0 | 3 |
| Theory with Tutorial | 2 | 1 | 0 | 3 |
| Practical | 0 | 0 | 4 | 2 |
| Project phase-I | 0 | 0 | 12 | 6 |
| Project phase-II | 0 | 0 | 24 | 12 |
| Total Number of Credits | | Between 70 to 75 | | |
| Number of credits per Semester | | Between 12 to 23 | | |

6.2 Course Numbering Scheme

Each course is denoted by a unique code consisting of 9 alphanumeric characters. The details of the numbering scheme are shown in Fig. 1.

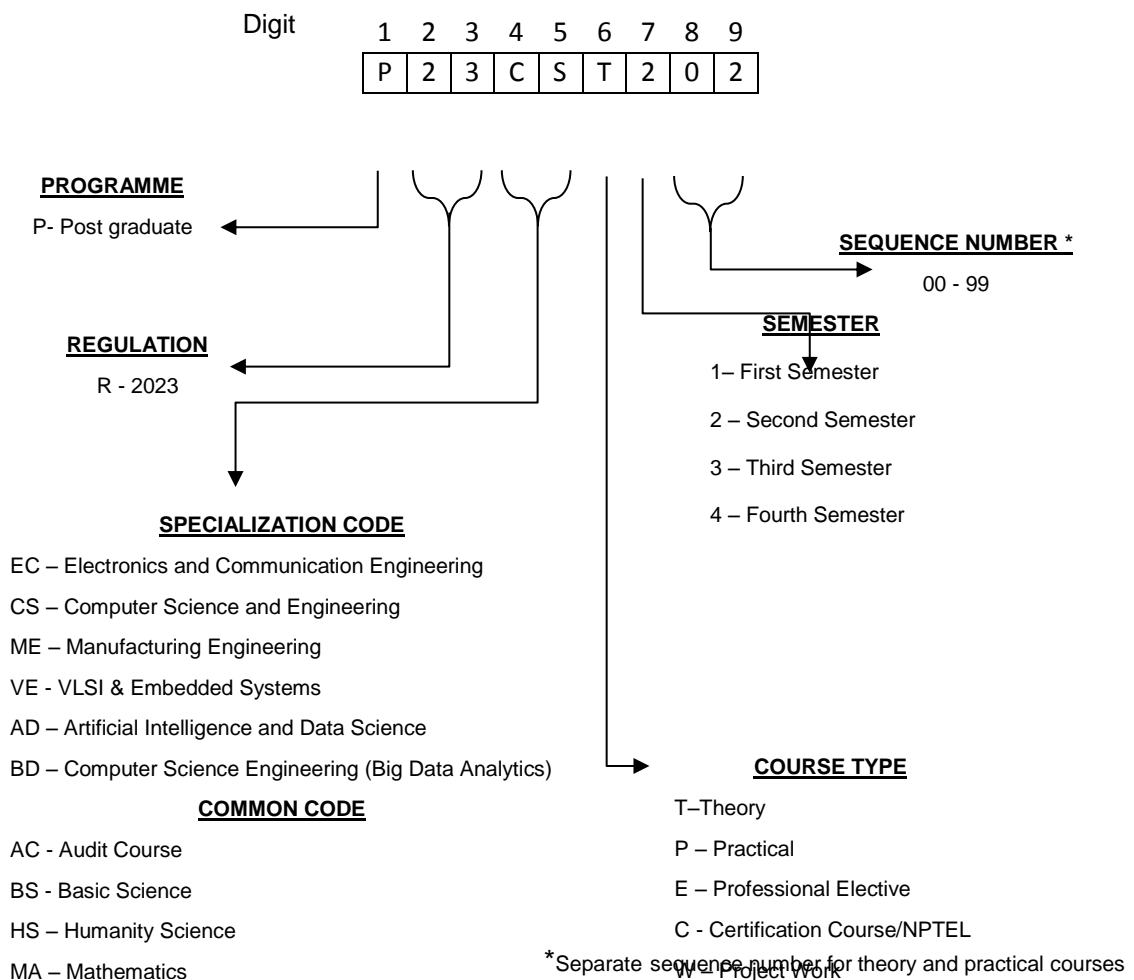

Fig. 1 Course code formation

6.3 Professional Electives

Each student shall choose a course from the professional elective list specified in the

curriculum relating to his/her degree programme in consultation with the Programme Academic Coordinator and the HoD.

6.4 Project Work

Each student shall be required to undertake a suitable project in industry / research organization / department in consultation with the Head of the Department and the project supervisor. A student shall register for the Project Phase I and II in 3rd and 4th semester respectively..

1. The process and guidelines for industry/Research organization projects

- (i) Students opting for the industry / research organization project should decide, identify and interact with relevant industry/ research organization in 2nd semester itself. Training and Placement cell shall help to establish contact with industries. Students shall take necessary help from their department for exact plan of action and apply to the industry / research organization through proper channel. The project coordinator shall decide the schedule appropriately.
- (ii) Students shall submit the application attached with relevant details viz. correspondence with industry, area and nature of project and its proposal to the department before the end of 2nd semester.
- (iii) Head of the Institution / Dean Academics / Dean R&D / Placement Officer shall issue permission letter to the students on the recommendation of HoD and supervisor. Students shall be allowed to do the final year project work in the industry.
- (iv) An internal supervisor from the department and mentor from the industry/ research organization where the project is to be undertaken shall be allocated to the students. Both supervisors should discuss and finalize the scope of the project work and monitor the progress together.
- (v) Internal supervisor should visit the industry a minimum of 3 times in a semester to see the progress of his/her students and a brief report should be submitted to the HoD about the progress.
- (vi) Students should maintain a record on the progress and get the approval from both internal and external supervisors at least twice in a month either by physically or through email communication. If the progress is not found satisfactory due to any reason, the supervisor should take the corrective action, after consulting with project coordinator and HoD.
- (vii) Progress report and certificate of completion of the project work from the industry / research organization shall be submitted by the students to the respective supervisor. The mode of evaluation shall be same as that of the in-house project.

2. The Process and guidelines for in-house project

- Project work will be assigned to a single student under the supervision of Project supervisor(s).
- Students execute their in-house project in the Department with proper approval from the HoD through the respective project supervisor.

6.5 Ability Enhancement Courses

6.5.1 Certification Courses: Students shall choose a National/International certification course of 40-50 hours duration specified in the curriculum, which will be offered through Centre of Excellence. These courses carry no credit and will not be considered for CGPA calculation.

6.5.2 Skill Development Courses: Skill development courses are non-credit courses, provided to enhance the knowledge and skill set of the students. It is mandatory for every student to register online courses like NPTEL / SWAYAM / MOOC etc. approved

by the Department committee comprising of HoD, Programme Academic Coordinator and Subject Experts. Students have to complete relevant online courses successfully. The list of online courses is to be approved by Academic Council on the recommendation of HoD at the beginning of the semester if necessary, subject to ratification in the next Academic council meeting. The Committee will monitor the progress of the student and recommend the grade (100% Continuous Assessment pattern) based on the marks secured in online examinations.

6.6 Audit Courses

The Audit courses namely English for Research paper writing, Disaster Management, Value education, Stress Management by Yoga, Constitution of India etc shall be included in semesters 1 and 2 of M.Tech Curriculum. These are non- credit courses having a minimum of 30 hours duration and students have to complete a minimum of 2 audit courses.

6.7 Industrial Training / Internship

Students may undergo training or internship during summer / winter vacation at Industry/ Research organization / University (after due approval from the Programme Academic Coordinator and Department Consultative Committee (DCC). In such cases, the internship/training should be undergone continuously (without break) in one organization. Normally no extension of time is allowed. However, DCC may provide relaxation based on the exceptional case. The students are allowed to undergo three to four weeks internship in established industry / Esteemed institution during vacation period.

7 COURSE ENROLMENT AND REGISTRATION

7.1 All the students of the M.Tech. programme shall register for the courses during a specified period in the beginning of the semester provided he/she fulfills the eligibility criteria prescribed for enrolment and registration of courses in that particular semester. List of students enrolled in a particular semester of a branch of study shall also include

- (i) Students who rejoin the programme after temporary break (vide Clause 14)
- (ii) Students who rejoin the programme after being stopped from moving to next higher semester due to non-fulfillment of attendance requirement (vide Regulation 9.2)
- (iii) After registering for all the courses, the student must attend the classes, satisfy the attendance requirements, earn Continuous Assessment Marks (CAM) and appear for the End Semester Examinations (ESE).

7.2 Pre-Registration: A list of open elective courses offered in the next higher semester will be made available to the students three week before Pre-Registration. Open Elective courses will be offered from fifth to seventh semester. In order to facilitate proper planning of open elective courses to be offered in a semester, it is essential for the students to declare their intent to register for an open elective course well in advance, before the actual start of the semester classes, through the process of Pre-Registration. A student can choose the open elective courses in consultation with the concerned Faculty Adviser.

7.3 Arrear Course Registration

- (i) In the first attempt of writing the End Semester Examination of a course if a student fails, He / She can retain the existing CAM and proceeds to write the End Semester Examinations / Supplementary exams as and when it is conducted.
- (ii) The student(s) will be allowed to write their arrear course(s) as per their Regulations till its existence and also the CAM will be valid till the existence of their regulations. There after the student(s) has to register for the arrear course(s) only for the equivalent course (s) prescribed by the respective board as per the Regulations in-force and student(s) will be assessed for the total 100 marks in the End Semester Examinations.

7.4 Rejoining

- (i) The candidate at the time of rejoining should follow the regulations which exists in-force.
- (ii) The candidate rejoining in new Regulations shall apply to the Head of the Institution in the prescribed procedure through the Head of the Department at the beginning of the readmitted semester itself for prescribing additional/equivalent courses in the regulations in-force, so as to bridge the curriculum in-force and the old curriculum.

7.5 Re-earn the Continuous Assessment Marks (CAM)

If a student wishes to re-earn the Continuous Assessment Marks (CAM), He / She has to re-register by paying the prescribed fee for the course in the subsequent semester. The student has to re-earn the CAM by taking-up all the internal tests, assignments and presentation as per the norms of regulations. However, the higher marks scored by the students in his/her attempts for CAM shall be considered.

8 ASSESSMENT PROCEDURES FOR AWARDING MARKS

The total marks for each course (Theory, Practical) comprising of two components namely Continuous Assessment Marks (CAM) and End Semester Examination Marks (ESM). However, Internship and Ability Enhancement Courses (certification course and skill development course) and audit courses have only continuous assessment for 100 marks without an End Semester Examination.

8.1. Theory Courses

All theory courses shall be assessed as per Table 8.1.

Table 8.1 Assessment method for Theory Courses

| Assessment | Continuous Assessment Marks (CAM) | | | | | End Semester Examination (ESE) Marks | Total Marks |
|------------|-----------------------------------|-------|------------|-------------|------------|--------------------------------------|-------------|
| | CAT 1 | CAT 2 | Model Exam | Assignment* | Attendance | | |
| Marks | 5 | 5 | 15 | 10 | 5 | 60 | 100 |

* Application oriented / Problem solving / Design / Analytical in content from Unit 5

i). Continuous Assessment:

Continuous Assessment Marks shall be based on attendance, Continuous Assessment tests and assignments.

a. Attendance:

Attendance carries 5 marks and the distribution of marks is as follows:

- 5 marks for 95% and above
- 4 marks for 90% and above but below 95%
- 3 marks for 85% and above but below 90%
- 2 marks for 80% and above but below 85%
- 1 mark for 75% and above but below 80%

b. Continuous Assessment tests:

Continuous Assessment test carries 25 marks. Performance in all the tests will be taken for assessment as follows:

Table 8.2 Weightage of Assessment for Theory Courses

| S. No | Test | Portion for Test | Test Marks | Duration of Test | Weightage for Internal Marks |
|--|------------|------------------------|------------|-------------------|------------------------------|
| 1 | CAT - 1 | 2 Units (Unit 1 and 2) | 40 | 1 hour 30 Minutes | 5 |
| 2 | CAT - 2 | 2 Units (Unit 3 and 4) | 40 | 1 hour 30 Minutes | 5 |
| 3 | Model Exam | All 4 Units | 60 | 3 hours | 15 |
| Continuous Assessment Tests Marks for Theory courses | | | | | 25 |

c. Assignments:

- Assignments carries 10 marks.
- The assignment should be in the form of Application oriented / Problem solving / Design / Analytical from Unit 5.

ii). End Semester Examination:

The duration of examination shall be 3 hours with a maximum of 60 marks.

iii). Question Paper Pattern for Theory courses

The question paper pattern of CAT, Model and End Semester Examination for Theory courses as per the Table 8.3 and 8.4 shall be followed.

Table 8.3 Question Paper pattern for CAT 1 and 2

| 2 Mark Questions | 10 Mark Questions | Total Marks |
|---|--|-------------|
| 5 (Atleast 2 questions from each Unit) | 3 (Out of 4 Questions and at least two questions from each Unit) | 40 |

Table 8.4 Model and End Semester Examination Question Paper pattern for 4 unit courses

| 2 Mark Questions | 12 Mark Questions | Total Marks |
|---|---|-------------|
| 6 (At least one question from each unit) | 4 (out of 6 Questions and at least one from each unit) | 60 |

8.2 Practical Courses:

All practical courses shall be assessed as per Table 8.5.

Table 8.5 Assessment method for practical courses

| Assessment | Continuous Assessment Marks (CAM) | | | | | End Semester Examination (ESE) Marks | Total Marks |
|------------|-----------------------------------|-------------|------|-----------------------------|------------|--------------------------------------|-------------|
| | Performance in practical classes | | | Model Practical Examination | Attendance | | |
| | Conduction of practical | Record work | viva | | | | |
| Marks | 15 | 5 | 5 | 15 | 10 | 50 | 100 |

i). Continuous Assessment:

Continuous Assessment Marks shall be based on attendance, regular performance of the student in practical classes and a model practical examination conducted at the end of the semester.

a. Attendance:

Attendance carries 10 marks and the distribution of marks is as follows:

- 10 marks for 95% and above
- 8 marks for 90% and above but below 95%
- 6 marks for 85% and above but below 90%
- 4 marks for 80% and above but below 85%
- 2 marks for 75% and above but below 80%

b. Performance in practical classes

The regular performance in the practical class (conduction of practical (15 marks), Record work (5 marks) and viva (5 marks)) will be evaluated for 25 marks.

c. Performance in the Model practical examination

Performance in the Model practical examination will be evaluated for 15 marks. The pattern of Model Practical Examination will be similar to the End Semester practical Examination.

ii). End Semester Examination:

The End Semester Examination of the practical courses will be evaluated for 50 marks by a panel of examiners comprising of an internal examiner and an external examiner. The Break-up of marks is as follows:

| | |
|---------------------------------|------------|
| Procedure / Algorithm | : 10 marks |
| Experiment / Program Execution: | 20 marks |
| Result / Output | : 10 marks |
| Viva-Voce | : 10 marks |

8.3 Final year Project (Phase I and II)

The Project work carried out in the third and fourth semesters shall be assessed as follows:

Table 8.6 Assessment method for Project work

| Assessment Method | Marks | |
|--|---------|----------|
| | Phase-I | Phase-II |
| Continuous Assessment (Internal Evaluation) | 50 | 50 |
| End Semester Examination (External Evaluation) | 50 | 50 |
| Total | 100 | 100 |

Criteria for Assessment of Project Work

- Interim project report shall be submitted before the project review with the approval of the supervisor. The Project Report prepared according to the approved guidelines and duly signed by the supervisor and the Head of the Department shall be submitted as per the timeline announced by the department.
- The End Semester Examination for the project work shall consist of an evaluation of the final project report by an external examiner, followed by a viva-voce examination conducted by a committee consisting of the external examiner and an internal examiner. The Controller of Examinations (CoE) shall appoint Internal and External Examiners for the End Semester Examination of the Project Work.
- The Continuous Assessment Marks (CAM) and End Semester Examinations marks (ESM) distribution for the Project Work is given in Table 8.7

Table 8.7 (a) CAM and ESM break-up for Project Phase - I

| Sl. No | Description | | Weightage |
|--------------------|--|-------------------------------|------------|
| 1 | Continuous Assessment Marks | | |
| a | Review 1 | Review Committee [#] | 10 |
| | | Supervisor | 5 |
| b | Review 2 | Review Committee [#] | 10 |
| | | Supervisor | 5 |
| c | Review 3 | Review Committee [#] | 15 |
| | | Supervisor | 5 |
| Total CAM | | | 50 |
| 2 | End Semester Marks | | |
| a | Evaluation of Phase I report and Viva-voce | | 50 |
| Total ESM | | | 50 |
| Total Marks | | | 100 |

Table 8.7 (b) CAM and ESM break-up for Project Phase - II

| Sl. No | Description | | Weightage |
|--------------------|---|---|------------|
| 1 | Continuous Assessment Marks | | |
| a | Review 1 | Review Committee [#] | 10 |
| | | Supervisor | 5 |
| b | Review 2 | Review Committee [#] | 10 |
| | | Supervisor | 5 |
| c | Review 3 | Review Committee [#] | 15 |
| | | Supervisor | 5 |
| Total CAM | | | 50 |
| 2 | End Semester Marks | | |
| a | Evaluation of final report and Viva-voce | Report | 10 |
| | | Presentation and Viva | 15 |
| | | Demonstration | 15 |
| b | Expected Outcome from the project ^{##} | Publication / communication of papers / prototypes/ patents etc | 10 |
| Total ESM | | | 50 |
| Total Marks | | | 100 |

[#] Review committee consists of internal faculty members nominated by the Head of the Department. The Supervisor of the student being examined shall not be part of the committee.

^{##} Expected Outcome from the project, in terms of paper publication, patents, product development and industry projects shall be awarded based on the document proof submitted by the student concerned

8.4 Industrial Training / Internship

8.3.1 The evaluation of 'Internship' is through internal assessment only (continuous assessment) as per Table 8.8.

8.3.2 A committee comprising of two faculty members appointed by Head of the Department will assess the internship for 100 marks.

Table 8.8 Assessment method for Industrial Training / Internship

| Assessment | Continuous Assessment Marks (CAM) | | Total Marks |
|------------|-----------------------------------|--------------|-------------|
| | Report | Presentation | |
| Marks | 50 | 50 | 100 |

8.5 Technical Report Writing and Seminar

The evaluation of Technical Report Writing and Seminar is through internal assessment only as per Table 8.9

Table 8.9 Assessment method for Technical Report Writing and Seminar

| Assessment | Continuous Assessment Marks (CAM) | | | | Attendance | Total Marks |
|------------|-----------------------------------|---------|--------|------|------------|-------------|
| | Weekly Progress | Seminar | Report | Viva | | |
| Marks | 40 | 30 | 10 | 10 | 10 | 100 |

8.6 Seminar on ICT: A Hands-On Approach

The evaluation of Seminar on ICT: A Hands-On Approach is through internal assessment only as per Table 8.10

Table 8.10 Assessment method for Seminar on ICT: A Hands-On Approach

| Assessment | Continuous Assessment Marks (CAM) | | | Attendance | Total Marks |
|------------|-----------------------------------|--------|------|------------|-------------|
| | Presentation using ICT | Report | viva | | |
| Marks | 50 | 30 | 10 | 10 | 100 |

8.7 Ability Enhancement Courses

8.7.1 Certification Courses

- (i) Certification Courses are required to be completed to fulfill the degree requirements. All **Certification** courses are assessed internally for 100 marks as per Table 8.11.
- (ii) The Course coordinator handling the course will assess the student through attendance and MCQ test, and declare the student as “pass” on satisfactory completion. A letter grade “P” is awarded to declare pass.
- (iii) The marks scored in these courses will not be taken into consideration for the SGPA / CGPA calculations in the grade sheet.

Table 8.11 Assessment method for Certification courses

| Assessment | Continuous Assessment Marks (CAM) | | Total Marks |
|------------|-----------------------------------|----------|-------------|
| | Attendance | MCQ Test | |
| Marks | 10 | 90 | 100 |

8.7.2 Audit Courses:

- (i) Audit Courses are required to be completed to fulfill the degree requirements. All Mandatory Courses are assessed internally for 100 marks as per Table 8.12.
- (ii) The faculty In-charge handling the course will assess the student through activities, quizzes and debates and declare the student as “pass” on satisfactory completion. A letter grade “P” is awarded to declare pass.
- (iii) The marks scored in these courses will not be taken into consideration for the SGPA / CGPA calculations in the grade sheet.

Table 8.12 Assessment method for Audit courses

| | | | | | |
|--|------------|-----------------------------------|----------|--------------------------------------|-------------|
| | Assessment | Continuous Assessment Marks (CAM) | | | Total Marks |
| | | Attendance | MCQ Test | Presentation / Activity / Assignment | |
| | Marks | 10 | 50 | 40 | 100 |

9 ELIGIBILITY FOR APPEARING END SEMESTER EXAMINATION

9.1 Requirements for Appearing End Semester Examination

A student is expected to maintain 100% attendance in all courses as attendance also carries internal marks. A student will be qualified to appear for end semester examinations in a particular course of a semester only if he/she satisfies the below mentioned requirements.

9.1.1 The student is permitted to appear for End Semester Examinations, only if he/she maintains minimum 75% of attendance. If he/she secured attendance greater than or equal to 60 % and less than 75% in any course in the current semester can be considered in case of the following reasons:

- i. Medical reasons (hospitalization / accident and or illness)
- ii. Due to participation in sports events or any competitions or NCC and / or NSS activities with prior written permission from the Head of the Institution / Dean Academics through the Head of the Department

He/she has to pay the necessary condonation fee prescribed by the college authority with necessary supporting documents for his/her absence.

9.1.2 The student shall be considered for exemption from the prescribed attendance requirement for the reasons stated above and if exempted, the student shall be permitted to appear for the End Semester Examination of that course. In all such cases, the students should have submitted the required documents on joining after the absence, to the Head of the Department through Programme Academic Coordinator

9.1.3 If any student is suspended for any reason during the semester, the days of suspension of a student on disciplinary grounds will be considered as days of absence for calculating the percentage of attendance for each individual course.

9.2 Movement to Next Higher Semesters

9.2.1 A student can move to the next semester provided only if he/she fulfills the minimum attendance requirement for appearing in the end semester examination.

9.2.2 The student who has failed to fulfill the above conditions will not be permitted to move to the higher semester, and shall rejoin the programme in the next academic year in the same semester after fulfilling all the requirements as per the regulations.

9.2.3 A student who rejoins the programme after the temporary break shall be governed only by the rules, regulations, course of study and syllabi in force, at the time of rejoining the course.

9.3 Provision for Withdrawal from Examination

9.3.1 Complete Withdrawal (applicable only for nil arrear students): A student, who is eligible to appear for the semester examinations, will be permitted to withdraw from appearing for the entire End Semester Examinations as one unit (*Complete*

Withdrawal) for valid reasons and on the recommendation of the Head of the Department and with the approval of the Dean Academics. Complete Withdrawal application shall be made before the commencement of the first examination pertaining to the semester. Such withdrawal shall be permitted **only once** during the entire programme.

9.3.2 A student who has completely withdrawn from appearing for End Semester Examinations in a particular semester should appear for the examinations of all the withdrawn subjects in the next semester itself.

9.3.3 If all other conditions are satisfactory, the candidate who withdraws is also eligible to be awarded DISTINCTION whereas he/she is not eligible to be awarded a rank.

9.4 Scribe for End Semester Examination

9.4.1 If any student is not in a position to write End Semester Examination on account of temporary physical disability or injury due to accident and applies for a scribe (writer) with medical certificate obtained from a medical officer not below the rank of Assistant Director level, then a scribe shall be allowed / assigned by CoE to such student. Normally, such scribe shall neither be a student nor a degree holder of any technical programme having similar competency. The student shall, however, apply in a prescribed proforma to CoE requesting permission for using the scribe well in advance, not on the day of examination, to make necessary arrangements (Scriber, Separate Examination Hall etc.). CoE shall take the undertaking from the scribe in a prescribed proforma. Such student shall produce the permission letter from the CoE for using scribe to the invigilator. He/She should pay the TA/DA and other charges to the scribe. Scribe shall be allowed extra time as per the norms specified by the Controller of Examinations.

9.4.2 Student admitted with differently abled category and those who can write, but at much slower speed as compared to normal student, he/she may be allowed an extra time of 30 minutes for 50 marks paper and 45 minutes for 60 marks paper to write the examination for all the courses. He/She shall seek permission from CoE for the extra time on account of his/her percentage of disability by producing necessary medical certificate from medical officer not below the rank of Assistant Director.

9.5 Malpractice in Examinations

If any student caught red-handed due to malpractices in examinations then he/she shall be punished as per the recommendations of the Complaint Redressal Committee (CRC) constituted by CoE with the approval of Head of the Institution. The CRC shall inquire and decide the punishment for the unfair means as specified in the Examination manual.

10 REQUIREMENTS FOR PASSING THE EXAMINATION

10.1 A student is declared to have successfully passed a theory based course if he/she has secured:

A minimum of 40% marks out of 75 marks in the End Semester Examinations and a minimum of 50% marks on combining both Continuous Assessment Marks (CAM) and End Semester Examination Marks (ESM).

10.2 A student is declared to have successfully passed a practical / project based course if he/she has secured:

A minimum of 50% marks in the End Semester Examinations and a minimum of 50% marks on combining both Continuous Assessment Marks (CAM) and End Semester Examination Marks (ESM).

10.3 For Industrial Training / Internship, mandatory and Ability Enhancement courses, a

student is declared to have successfully passed the course if he/she secured minimum of 50% marks in Continuous Assessment Marks (CAM).

11 EVALUATION AND GRIEVANCE REDRESSAL MECHANISM

11.1. Grievances related to the entire process of Continuous Assessment shall be addressed to Academic Appeal Board as given in Regulations under Clause 18.4.

11.2. Grievances related to End Semester Examination of Theory Courses for regular and arrear examinations can be redressed as follows:

11.2.1. Photocopy of the Answer Script:

After declaration of results, photocopy of valued answer scripts with the marks awarded to individual answers shall be made available to the students on submission of an application along with the prescribed fees to the Controller of Examinations.

11.2.2. Revaluation:

Students can apply for revaluation by submitting an application along with the prescribed fees to the Controller of Examinations. The revaluation is extended to the students those who have maximum of two arrears in theory papers.

12 LETTER GRADE AND GRADE SHEET

All assessments of a course will be evaluated exactly based on the marks. However, for the purpose of reporting the performance of a candidate, letter grades, each carrying certain number of points, will be awarded as per the range given in Table 8, based on the percentage of marks obtained by the candidate in each subject.

Table 8 Letter Grade and its range

| S. No | Range of total marks | Letter Grade | Grade Points |
|-------|-----------------------------|--------------|--------------|
| 1 | 90 to 100 | S | 10 |
| 2 | 80 to 89 | A | 9 |
| 3 | 70 to 79 | B | 8 |
| 4 | 60 to 69 | C | 7 |
| 5 | 55 to 59 | D | 6 |
| 6 | 50 to 54 | E | 5 |
| 7 | 0 to 49 | F | 0 |
| 8 | Absent | FA | 0 |
| 9 | Withdrawal from examination | W | 0 |
| 10 | Pass in non-credit course | P | 0 |

F – denotes Failure of the course and FA – Failure due to Absent

12.1 Grade Sheet

After declaration of results, grade sheets will be issued to each student, which will contain the following details:

- The College Name and Affiliating University.
- The list of courses registered during the semester and the grades scored.
- The Semester Grade Point Average (SGPA) for the semester.
- The Cumulative Grade Point Average (CGPA) of all courses enrolled from first semester onwards.
- On completion of a semester, each student is assigned a Semester Grade Point Average which is computed as below for all courses registered by the student during that semester

$$\text{Semester Grade Point Average (SGPA)} = \frac{\sum_i (C_i \times GP_i)}{\sum_i C_i} \quad i = 1 \text{ to } n;$$

Where n= Number of credit courses in that semester.

C_i is the Credit of i^{th} course in that semester and GP_i is the Grade Point earned by the student for that i^{th} course. The SGPA is rounded off to two decimals.

- The overall performance of a student at any stage of the Degree programme is evaluated by the Cumulative Grade Point Average (CGPA) up to that point of time.

$$\text{Cumulative Grade Point Average (CGPA)} = \frac{\sum_i (C_i \times GP_i)}{\sum_i C_i} \quad i = 1 \text{ to } m;$$

Where m = Number of credit courses from 1st semester to the completed semesters, C_i is the Credit of i^{th} course of the completed semesters at that stage and GP_i is the Grade Point earned by the student for that i^{th} course.

12.2. Scheme for conversion of CGPA to Percentage (%) marks:

A scheme to convert the Cumulative Grade Point Average (CGPA) to Percentage (%) of marks is shown below:

$$\text{Percentage (\%)} \text{ marks} = \text{CGPA} \times 10$$

13 ELIGIBILITY FOR THE AWARD OF DEGREE

A student shall be declared to be eligible for the award of M.Tech. Degree provided the student has successfully completed the course requirements and has passed all the prescribed End Semester Examinations in all the four semesters within a maximum period of 4 years calculated from the commencement of the first semester.

13.1 Classification of Degree

After successful completion of the programme, degree will be awarded as per the following classifications based on the final CGPA

1. First class with Distinction

Student who satisfies the following conditions shall be declared to have passed the End Semester Examination in *First class with Distinction*:

- Students who have successfully completed the programme within four consecutive semesters and obtained a final CGPA of 8.5 or above by passing the End Semester Examination in all the courses (Theory and Practical) from first to fourth semester in the *first attempt* will be declared to have passed in **First Class with Distinction**.
- Students who have secured a final CGPA of 8.5 or above but failed to clear the courses offered from first to fourth semester in the first attempt are not eligible for **First Class with Distinction** classification. However,

Students who have opted for authorized complete withdrawal (only one time) from examination will also be eligible for **First Class with Distinction** classification but it will not be considered for Ranking.

2. First class

A student who satisfies all the following conditions shall be declared to have passed the examination in First class:

- Should have passed the examination in all the courses of all four semesters within two years
- Should have obtained a final CGPA not less than 6.5 shall be declared to have

passed in **First Class**.

- (c) Students who have lost the eligibility for **First Class with Distinction** classification by failing to clear the courses offered from 1st to 4th semesters in the first attempt but securing a final CGPA of 8.5 or above shall also be declared to have passed in **First Class**.

3. Second class

All other students (not covered in clauses at S.No.1 and 2 under Clause 13) who qualify for the award of the degree shall be declared to have passed the examination in Second Class.

13.2 Gold Medals and Ranks

For the Award of Gold Medal and ranks for each branch of study, the CGPA secured from 1st to 4th semester should be considered and it is mandatory that the candidate should have passed all the subjects from 1st to 4th semester in the first attempt. Rank certificates would be issued to the first two candidates in each specialization.

14 TEMPORARY BREAK OF STUDY FROM THE PROGRAMME

A student shall be permitted to withdraw temporarily from the college for the reason beyond his/her control. The applicable rules are:

- i. After withdrawal, the student shall rejoin next year in the same semester during which the student has withdrawn.
- ii. The student shall apply to Dean Academics through HoD stating the reasons for withdrawal, along with supporting documents, consent letter from his/her parent/guardian and clearance/no due from all the concerned departments.
- iii. Dean Academics shall examine the case and recommend for the approval/ratification from Academic Council (AC) /Academic Standing Committee (ASC).
- iv. A student availing temporary withdrawal from the college under the above provision shall be required to pay such fees and/or charges as may be fixed by the AC/ASC for his/her name to be enrolled. However, it may be noted that the fees/charges once paid shall not be refundable.
- v. The total period of completion of the course reckoned from the commencement of the first semester to which the candidate was admitted shall not exceed 4 years in any case including of the period of discontinuance.

15 TERMINATION FROM THE PROGRAMME

A student shall be terminated from the program in the following cases:

- i. Involved in ragging and not obeying disciplinary rules structured by college.
- ii. Not completing the programme in prescribed period; Students shall have to complete M. Tech programme in the maximum period of 4 years (8 semesters) from the date of admission. If not completed, such student will be declared as Failed to Complete Technical Education (FCTE). However, genuine cases with proper justification may be referred to AC for extending programme completion period.

16 DISCIPLINE AND CONDUCT

16.1 Any act of misconduct committed by a student inside or outside the campus shall be an act of violation of discipline of the college. Violations of the discipline shall include:

- (a). Interference to teaching, examination, administrative work, curricular or extra-curricular activities and any act likely to cause disruption.
- (b). Damaging or defacing the property inside or outside the college campus.
- (c). Engaging in any attempt at wrongful confinement of teachers, employees and

students of the college.

- (d). Use of abusive and derogatory slogans or intimidators' language or incitement of hatred and violence.
- (e). Ragging in any form ("Ragging means causing, inducing, compelling or forcing a student whether by way of a practical joke or otherwise to do any act that detracts from human dignity or violates his person or exposes him to ridicule or to forbear from doing lawful act, by intimidating, wrongfully re-straining wrongfully confining or injuring him or by using criminal force to him or by holding out to him any threat of such intimidation, wrongful restraint, wrongful confinement, injury or the use of criminal offense), as per the directions of Supreme Court of India, is a criminal offence.
- (f). Eve teasing or disrespectful behavior to a student.
- (g). An assault upon or intimidation of, or insulting behavior towards a teacher, officer, employee or student or any other person.
- (h). Getting enrolled in more than one programme /course of study simultaneously.
- (i). Committing forgery, tampering the documents or records, identity cards, furnishing false certificate or false information.
- (j). Organizing instant agitation/meetings without prior permission in the campus.
- (k). Viewing/downloading obscene information/data, images and executable files, sending obscene mails/messages via Facebook/twitter/ other social sites using college servers/personal electronic gadgets in the college premises.
- (l). Sharing the login and password and other details of IT facilities provided to other outside students.
- (m). Refusing to provide an identity card when demanded by any teacher / college authority.
- (n). Consuming or possessing alcoholic drinks, dangerous drugs or other intoxicants in the college campus.
- (o). Possessing or using any weapons and fire arms in the college campus.
- (p). Encroachment of hostel, accommodating guests or other persons in hostels without permission.
- (q). Malpractice in examination
- (r). Indulging in anti-national activities contrary to the provisions of acts and laws enforced by Government.
- (s). Any other act which may be considered by the Head of the Institution or the Discipline Committee to be an act of violation of discipline.

16.2 Any act of indiscipline of a student reported to the Head of the Institution shall be referred to Redressal and Disciplinary Committee of the college. The Committee shall enquire into the charges and recommend suitable punishment if the charges are substantiated. The penalties / punishment / actions may include:

- (a). Written warning and information to the parents/guardian.
- (b). Imposition of fine
- (c). Suspension from the College/Hostel/Mess/Library or availing of any other facility.
- (d). Suspension or cancellation of scholarship/fellowship / studentship or any financial assistance from any source.

- (e). Recover of loss caused to college property.
- (f). Debarring from participation in sports/NSS/student club activities.
- (g). Disqualifying from holding any representative position in the Class / College / Hostel Mess / Sports / Clubs and in similar other bodies.
- (h). Disqualifying from appearing in placement and receiving any awards.
- (i). Expulsion from the Hostel/Mess/Library/Club/College for a specified period by forfeiting fees.
- (j). Debarring from appearing for an End Semester Examination.

16.3 Student(s) involved in any act of indiscipline /malpractice in examination shall be issued notice to him/her, asked to be present before the Complaint Redressal Committee (CRC) on the day at specified time and venue with his/her parents/guardian. He / She shall give written reply /oral explanation to the charges levied against him/her for consideration. If the implicated student(s) fails to appear before the committee, then decision shall be taken as absent, on the basis of available evidence/documents which shall be binding on the concerned student.

16.4 Every admitted student shall be issued photo identification (ID) card which must be worn by the students when he / she is inside in the college campus / college bus.

17 ACADEMIC CALENDAR

17.1 The academic activities of the college shall be governed by the academic calendar prepared for each academic semester and approved by the AC/ASC. It shall be notified at the beginning of each academic semester. Academic calendar shall incorporate schedule of admission, course registration, course delivery, examination / evaluation, course feedback, course/graduate exit survey, co-curricular activities.

17.2 The curriculum shall be typically delivered in two semesters in an academic year. Each semester shall be of 16 weeks (approximately 75 working days) duration, including evaluation, grade moderation and result declaration. Generally, 13-14 weeks (65-70 days) for course content delivery and 4-6 weeks (20 – 30 days) for examination /evaluation shall be assigned in each semester. The academic session in each semester shall provide at least 75 teaching days with 40 hours per week. The odd and even semesters of an academic year normally begin from second week of June and second week of December respectively.

17.3 The academic calendar should be strictly adhered to all other activities including co-curricular and extra-curricular activities that should be scheduled so as not to interfere with the curricular activities as stipulated in the academic calendar.

18 VARIOUS COMMITTEES AND ITS FUNCTIONS

18.1. Academic Council (AC)

COMPOSITION OF ACADEMIC COUNCIL:

1. The Principal (Chairman)
2. All the Heads of Departments in the Autonomous College
3. Four teachers of the Autonomous College representing different categories of teaching staff by rotation on the basis of seniority of service in the College.
4. Not less than four experts/academicians from outside the Autonomous College representing such areas as Industry, Commerce, Law, Education, Medicine, Engineering, Sciences, etc., are to be nominated by the Governing Body.
5. Three nominees of the University, not less than Professors.

6. The Controller of Examination of the Autonomous College
7. A faculty member nominated by the Principal (Member Secretary).

Term: The term of the nominated members shall be three years.

Meetings: Meetings of the Academic Council shall be held at least once every six months.

Functions of the Academic Council:

- (a) To scrutinize and approve the proposals with or without modification of the Board of Studies with regard to courses of study, academic regulations, curricula, syllabi and modifications thereof, instructional and evaluation arrangements, methods, procedures relevant thereto, etc., provided that where the Academic Council differs on any proposal, it shall have the right to return the matter for reconsideration to the Board of Studies concerned or reject it, after giving reasons to do so.
- (b) To make regulations regarding the admission of students to different programmes of study in the Autonomous College, keeping in view the policy of the Government.
- (c) To make regulations for sports, extra-curricular activities, and proper maintenance and functioning of the playgrounds and hostels.
- (d) To recommend to the Governing Body proposals for the institution of new programmes of study.
- (e) To recommend to the Governing Body institution of scholarships, studentships, fellowships, prizes, and medals, and to frame regulations for the award of the same.
- (f) To advise the Governing Body on suggestions(s) pertaining to academic affairs.
- (g) To perform such other functions as may be assigned by the Governing Body.

18.2 Board of Studies (BoS)

Composition of Board of Studies:

1. Head of the Department concerned (Chairperson).
2. All faculty members of the Department.
3. Two subject experts from outside the parent University are to be nominated by the Academic Council.
4. One expert is to be nominated by the Vice-Chancellor from a panel of six recommended by the Autonomous College Principal.
5. One representative from industry/corporate sector/allied areas to be nominated by the Principal.
6. One member of the College alumni to be nominated by the Principal.
7. Experts from outside the Autonomous College, whenever special courses of studies are to be formulated, to be nominated by the Principal.

Term: The term of the nominated members shall be three years.

Meetings: Meetings of the Board of Studies shall be held at least once every six months.

Functions:

The Board of Studies shall recommend the following to the Academic Council:

1. Courses of studies
2. Measures for the improvement of the standards of teaching and research
 - (a). Any other academic matter.

18.3 Academic Standing Committee (ASC)

Composition of Academic Standing Committee is same as that of AC, except external

members. ASC shall perform the functions under emergency situations subject to ratification by the AC.

18.4 Academic Appeal Board (AAB)

The Academic Appeal Board is constituted with Dean Academics as convener and two senior level professors as members, and the concerned Head of the Department and Class Advisor as co-opted members. The board will receive the grievances/complaints in writing from the aggrieved student regarding anomaly in award of marks. The board will examine the complaints and recommend appropriate measures to the Head of the Institution, for necessary action.

The entire process of Continuous Assessment shall be made transparent, in which students can get the explanation of marks being awarded from the course instructor, if and when required. However, if a student finds some anomaly in the award of marks in the continuous assessment, he/she can make an appeal to the *Academic Appeal Board* for review of marks awarded. Before appealing for such review, a student shall first approach the concerned Course Instructor and then the concerned Head of the Department, with a request to do the needful. Only after exhausting the above options and in situations where satisfactory actions / remedial measures have not been taken, the student may appeal to the Academic Appeal Board.

18.5 Departmental Advisory Committee (DAC)

DAC is another basic constituent of the academic system of an autonomous college. The composition and functions of the DAC are given below:

1. Chairperson: Head of the concerned Department
2. Internal Members: Two senior faculty members of the department
3. Industry Representative : One representative from industry/corporate sector / is related to the placement
4. One academician from other Institution
5. One meritorious alumnus
6. One parent
7. One student
8. Member secretary : Programme Academic Coordinator

Term: The term of the nominated members shall be three years.

Meetings: The meeting may be scheduled as and when necessary, but at least twice a year.

Functions of DAC

The DAC of a department in the college shall

- (a). Formulate a process to review post implementation effects of curriculum.
- (b). Suggest measures to ensure academic standard and excellence of the course offered by the department.
- (c). Suggest the methodologies for innovative teaching and evaluation techniques; enhancement of industry institute interaction.
- (d). Identify and recommend the record of new programme.
- (e). Review target set for attainment of course outcomes and programme outcomes.
- (f). Guide and provide support to department for enhancing interaction with outside world.
- (g). Plan strategically to enhance the academic quality of department.

- (h). Resolve the address issues expressed by the stakeholders through feedback.
- (i). Defining and redefining the Programme Educational Objectives (PEOs) and Programme Outcomes (POs) based on the recommendations by department academic committee.
- (j). Study the achievement of PEOs and POs reported by department evaluation committee and suggest measures for improvement.

18.6 Board of Examinations (BoE)

Composition

1. Head of the Institution (Chairperson)
2. Dean Academics
3. Controller of Examination(CoE): Member Secretary
4. One expert possessing ten years of industrial/ field experience nominated by the Chairman
5. Coordinators (Examinations, Assessment, Results and Tabulation)

Functions of BoE:

- (a). The BoE shall
 - i. Ensure proper performance of the various duties in conducting examinations viz. paper setting, time table preparation, assessment and declaration of results.
 - ii. Recommend examination reforms and shall implement after the approval of academic council.
 - iii. Prepare the detailed time table of examinations as per the schedule approved by academic council.
 - iv. Arrange for strict vigilance during the conduct of examination so as to avoid use of unfair means by the students, faculty and invigilators.
- (b). Chairman, BoE shall constitute Complaint Redressal Committee (CRC) consisting of three members as and when required to deal with the complaints related to the conduct of examinations.
- (c). The recommendations of the CRC shall be approved by Chairman for the BoE to take appropriate disciplinary actions in the concerned matter. The disciplinary actions shall be endorsed by the BoE.
- (d). The BoE shall perform duties and responsibilities that are assigned by Academic Council of the institute from time to time.

18.7 Department Consultative Committee (DCC)

Composition

1. Head of Department (Chairperson)
2. Five faculty members (at least one from each specialization) nominated by HOD
3. Member Secretary: Programme Academic Coordinator / Programme Evaluation Coordinator

Functions of DCC

- (a). Review, revise and prepare curriculum structure based on institutional policy, suggest improvements in syllabus of a course/s prepared by course teacher/s and

forward the curriculum to BoS for further recommendations.

- (b). Check appropriateness of course objectives, course outcomes, and mapping of COs with POs and suggest necessary improvements/modifications.
- (c). Monitor the academic progress throughout the semester, conduct of classes and take appropriate corrective measures to improve the quality of curriculum delivery.
- (d). Review academic performance of students.
- (e). Counsel the concerned course teachers for improvement based on student feedback, academic and question paper audit reports.
- (f). Verify the attainment level of course outcomes and programme outcomes.
- (g). Formulate strategy to collect feedback from stake holders, analyze the collected feedback and forward the analysis to DAC.
- (h). Contribute to maintain academic standard as well as improving the quality of the courses offered by the department and enhance industry–institute interaction.
- (i). Suggest open and professional electives considering societal needs.
- (j). Recommend methodologies for innovative teaching and evaluation techniques to BoS.
- (k). Coordinate research, teaching, extension and other academic activities in the department/college.
- (l). Carry out preparatory work for defining /redefining the Programme Educational Objectives (PEOs) and Programme Outcomes (POs) periodically.
- (m). Monitor evaluation of course attainments leading to achievement of programme outcomes and report the results of assessment to BoS.

18.8 Programme Academic Coordinator (PAC)

The functions and duties of PAC are:

- (a). Coordinating all academic activities of the department viz Curriculum revision, framing of syllabus, time table, member secretary for BoS meeting, re-registration of course/s, display and submission of attendance status.
- (b). Conducting internal academic audit and department advisory committee meeting as a member secretary.
- (c). Monitoring the academic activities and conduct of classes.
- (d). Extending necessary help to department academic and evaluation committee.
- (e). Recording and forwarding all academic related documents to Dean Academics.
- (f). Working in association with Dean Academics.

18.9 Departmental Evaluation Coordinator (DEC)

The functions and duties of DEC are:

- (a). Conduct course and graduate exit survey, make arrangements for feedback from stakeholders (industry/employer/alumni/student) and feedback analysis.
- (b). Monitor the assessment of course outcome.
- (c). Compute / assess / evaluate the achievement of PEOs and POs as per NBA/NAAC requirements.
- (d). Compile the information required for the preparation of Annual Quality Assurance Report (AQAR) by the Internal Quality Assurance Cell (IQAC).

- (e). Extend necessary help to department academic and evaluation committee.

18.10 PG Coordinator

Head of the Department will allot one faculty member to be the PG Coordinator for a particular batch of students throughout their period of study. The role of PG Coordinator is as follows:

- i. To motivate and closely monitor the performance of the students.
- ii. To build a strong alumni base for the institution by maintaining a possible rapport with students and parents.
- iii. To maintain all important documents of the students for reference/inspection by all committees.
- iv. To work closely with the student counselors on matters related to students and update the details from time to time in student's profile for further reference.
- v. To guiding and counseling students, faculty can create a greater sense of belongingness amongst the student community. To help the students in planning their courses and for general guidance on the academic programme,

18.11 Quality Circle Meeting (QCM)

Every class will have a class committee constituted by the HoD to discuss about the various Academic activities through Quality Circle Meeting (QCM). The members of the class committee will be as follows:

1. Chairperson (a senior faculty who is preferably not teaching any course for the class)
2. All the course handling staff of the class
3. Students (a minimum of 6 consisting of 3 boys and 3 girls on pro-rata basis)

Functions

The functions of the QCM shall include the following: -

- (a). Clarify the regulations of the programme and the details of rules therein.
- (b). Inform the student representatives about the academic schedule including the dates of assessments and the syllabus coverage for each assessment.
- (c). Inform the student representatives about the details of Regulations regarding marks assigned for each assessment. In the case of practical courses (laboratory/ project work / seminar etc.) the breakup marks for each experiment / exercise / module of work, should be clearly discussed in the class committee meeting and informed to the students
- (d). Analyze the performance of the students of the class after each assessment test and initiate steps for improvement.
- (e). Identify slow learners, if any, and request the faculty concerned to provide additional help / guidance / coaching to such students.
- (f). Discuss and sort out problems experienced by students in the classroom and in the laboratories.
- (g). The class committee shall be constituted within the first week of the commencement of any semester.
- (h). The chairperson of the class committee may invite the class advisor / student counselor and the Head of the Department to the meeting of the class committee.
- (i). The Head of the Institution may participate in any class committee meeting.

(j). The chairperson is required to prepare the minutes of every meeting, submit the same through the Head of the Department to the Principal within two days of the meeting and arrange to circulate the same among the students and faculty concerned. Points requiring action by the management shall be brought to the notice of the management by the Principal.

Meetings

Quality Circle Meeting (QCM) are to be conducted as scheduled below.

| | |
|-----------|---|
| Meeting 1 | One week before the 1 st assessment test |
| Meeting 2 | One week before the 2 nd assessment test |
| Meeting 3 | One week before the 3 rd assessment test |

During the first meeting of the class committee, the students are to be informed about the assessment procedure as per the framework of the Regulations. During these meetings the student representatives shall meaningfully interact and express opinions and suggestions of the students of the class to improve the effectiveness of the teaching-learning process.

19 REVISION OF REGULATIONS AND CURRICULUM

The college may revise, amend or change the regulations of curriculum and syllabi from time to time as and when found necessary.